

Power Quality Improvement in Deregulated Power System by Using Active Filters

G. Ravindra, M. Gopi Siva Prasad, Dr. M. Surya Kalavathi

Abstract-- This Research Proposal Explains introduces the terminology and various issues related to 'power quality'. The interest in power quality is explained in the context of a number of much wider developments in power engineering: deregulation of the electricity industry, increased customer-demands, and the integration of renewable energy sources. After an introduction of the different terminology two power quality disturbances are discussed in detail: voltage dips and harmonic distortion. For each of these two disturbances, a number of other issues are briefly discussed, which are characterization, origin, mitigation, and the need for future research. Shunt, hybrid and series active power filters are described showing their compensation characteristics and principles of operation. Different power circuits topologies and control scheme for each type of active power filter are analyzed.

Index terms-- Power quality, voltage sag voltage Swell, voltage fluctuations, Active filters.

1 INTRODUCTION

THE proliferation of microelectronics processors in a wide range of equipments, from home VCRs and digital clocks to automated industrial assembly lines and hospital diagnostics systems has increased the vulnerability of such equipment to power quality problems [1]. These problems include a variety of electrical disturbances, which may originate in several ways and have different effects on various kinds of sensitive loads. What were once considered minor variations in power, usually unnoticed in the operation of conventional equipment, may now bring whole factories to standstill. As a result of this vulnerability, increasing numbers of industrial and commercial facilities are trying to protect themselves by investing in more sophisticated equipment to improve power quality [2]. Moreover, the proliferation of nonlinear loads with large rated power has increased the contamination level in voltages and currents waveforms, forcing to improve the compensation characteristics required to satisfy more stringent harmonics standard [3],[4]. Between the different technical options available to improve power quality, active power filters have proved to be an important alternative to compensate for current and voltage disturbances in power distribution systems [5],[6], [7]. Different active power filters topologies have been presented in the technical literature,

[8] [9] and many of them are already available in the market [1], [2]. This paper will focus in the analysis of which to use

with their compensation characteristics. Shunt active power filters, series active topologies, and hybrid schemes will be presented and analyzed. The control scheme characteristics for shunt and series schemes will also be discussed. Finally, steady state and transient results for dynamic compensation,

obtained from simulated and experimental setup will be presented

2 NECESSITY OF POWER QUALITY

Power quality is an increasingly important issue for all businesses. Problems with powering and grounding can cause data and processing errors that affect production and service quality.

2.1 Lost production

Each time production is interrupted, your business loses the margin on the product that is not manufactured and sold.

2.2 Damaged product

Interruptions can damage a partially complete product, cause the items to be rerun or scrapped. Maintenance, reacting to a voltage disruption can involve restoring production, diagnosing and correcting the problem, clean up and repair, disposing of damaged products and, in some cases, environment costs.

2.3 Hidden costs

If the impact of voltage sag is a control error, a product defect may be discovered after customer delivery. The costs of losing repeat sales, product recalls and negative public relations can be significant and hard to quantify. A recent study by IBM showed that power quality problems cost U.S. businesses more than \$15 billion a year. That's an average of \$79,000 for each company.

3 POWER QUALITY

"Power quality" is defined as "the concept of powering and grounding electronic equipment in a manner that is suitable to the operation of the equipment in a manner that is suitable to the operation of that equipment and compatible with the premise wiring system and other connected equipment.

Power quality has become a strategic issue for the following reasons:

1. The economic necessity for businesses to increase their competitiveness.

- G.Ravindra is currently working as Assistant Professor in department of EEE in SVEC Tirupati, PH-9985886785 E-mail: g.ravindraeee@gmail.com
- M.Gopi siva prasad currently working as Assistant Professor in department of EEE in SIET, Tirupati, E-mail:gopieps@gmail.com
- Dr.M.Surya kalavathi is currently working as professor in the department of EEE in JNTU, Hyderabad PH-9440763393, E-mail:munagala12@yahoo.co.in

2.The widespread use of equipment which is sensitive to voltage disturbances and /or generates disturbances itself.

3.The deregulation of the electricity market. In this context, it is essential for the utility and the customers to prevent and detect power quality problems and to have solutions available to fix them.

4.The power quality correction and harmonic filtering system give solution to solve the problems of harmonic disturbances and voltage fluctuations.

3.1 Power Quality Glossary

Although specialists use complex equations for precise descriptions and analysis, the following definitions are adequate for most discussions with your local utility account managers, distribution engineers, and PQ consultants and vendors.

3.2 Harmonic distortion

Continuous or sporadic distortions of the 60-hertz (Hz) voltage sine waveform, usually caused by microprocessor based loads in the building such as computer power supplies, lighting ballasts, and electronic adjustable speed drives. Harmonics can also be transmitted from an energy user down the block. These can cause telecommunications or computer interference; overheating in motors, transformers, or neutral conductors; decreased motor performance; deterioration of power factor-correction capacitors; or erratic operation of breakers, fuses, and relays.

3.3 Interruption, momentary

A very short loss of utility power that lasts up to 2 seconds, usually caused by the utility switching operations to isolate a nearby electrical problem.

3.4 Long-term outage

A loss of utility power lasting more than 2 minutes due to major local, area, or regional electrical events.

3.5 Noise

Sporadic voltage changes consisting of frequencies higher than the normal 60-Hz power frequency due to any number of Causes, including arc welders, loose wiring, and nearby radio and TV transmitters.

3.6 Sag

A short-term decrease in voltage lasting anywhere from milliseconds up to a few seconds. Sags starve a machine of the electricity it needs to function, causing computer crashes or equipment lock-ups. Usually caused by equipment start-up—such as elevators, heating and air-conditioning equipment, compressors, and copy machines—or nearby short circuits on the utility system.

3.7 Spike

A very brief (nanoseconds to milliseconds) change in voltage ranging from tens to thousands of volts. Can be produced by utility and customer equipment operations, nearby lightning strikes, falling tree limbs on power lines, and even static dis-

charges.

3.8 Surge

A short-term increase in voltage, lasting up to a few seconds. They are due either to customer equipment operation, such as air conditioners or motors switching on and off, or to utility activities, such as capacitor switching.

3.9 Transient

A sudden momentary change in voltage. Also called a spike.

4 VOLTAGE SAG

Voltage sag is a sudden reduction (between 10% and 90%) of the voltage magnitude at a point in the electric System and lasting from 0.5 cycles to few seconds. Either switching operations or any type of faults as well as fault clearing process can cause a voltage dip. Switching like those associated with a temporary disconnection of the supply or flow of heavy currents associated with the starting of large motor loads is the most common. These events maybe originated at the utility side or at the customer site.

5 HARMONIC ELIMINATION TECHNIQUES

To avoid the ill effects of harmonics on the operation of sensitive equipments, it is necessary to keep harmonic contents below safe limit by installing filter at load end. The simplest way of eliminating harmonics of different orders is to install filters at the location generated by different loads are connected in two ways in power system network.

5.1 Series Connected Filters

Such type of filters are connected in series with power system network and offer high impedance at turning frequencies high impedance offered by filters allow very little harmonics are passed. The drawback of series filters are high cost, because the rating of filter component required is rated full load current.

5.2 Shunt Connected Filters

It is most commonly used filters in A.C. power system network and offers very low impedance path to harmonics. Shunt type of filters are cheaper than series type because the shunt connected filters are designed for graded insulation levels which makes the components cheaper than the series filter components. Following are the different techniques used to eliminate harmonics of different orders to keep harmonic distortion within permissible limit.

5.3 Passive Filters

These are LC resonating or parallel resonating circuits which offer very high or low impedance at tuning frequency. These filters are resistive at tuned frequency, capacitive at below tuned frequencies and inductive beyond

tuned frequency.

Series passive filters are connected in series and offers very high impedance to different harmonics at tuned frequency, because of its very high cost such type of filters are not used. Shunt passive filters are connected between line and earth and offer very low impedance at resonant frequency. Hence particular harmonic or harmonics directed to earth and prevented from passing further. The high pass shunt filters are connected to the point of common coupling block all over the harmonic frequency and passes all higher frequency.

5.4 Shunt Active Power Filters

The voltage source inverter (VSI) based shunt active power filter has been use in recent years. The operation principle of shunt active power filter can be regarded as a current source produces current harmonics. These components are equal to magnitude of current harmonics and opposite in phase this principle is applicable to any type of load considered a harmonic source. The Fig 1 shows the structure and compensation characteristics of shunt active power filter.

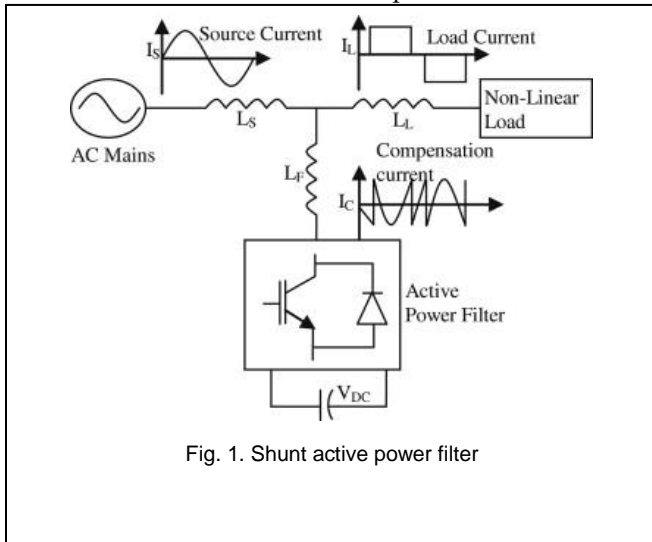

Fig. 1. Shunt active power filter

5.5 Series Active Power Filters

The Fig.2 shows the basic block diagram of series active power filter that is connected before the load in series with the mains, Using a matching transformer, to eliminate voltage harmonics to malance and regulate the terminal voltage of the load or line. It can be installed by electric utilities to compensate voltage harmonics and dampout harmonic propagation caused by resonance with line impedances and passive shunt compensators.

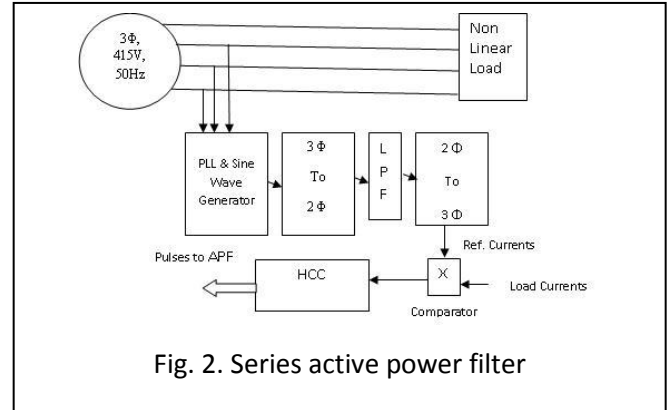

Fig. 2. Series active power filter

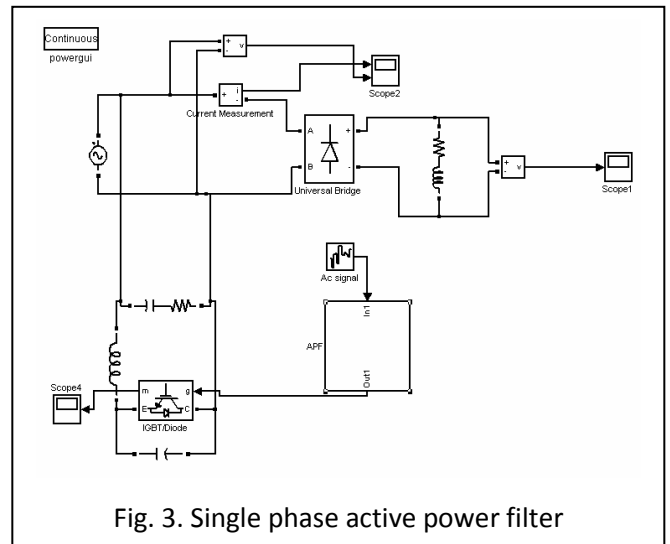

Fig. 3. Single phase active power filter

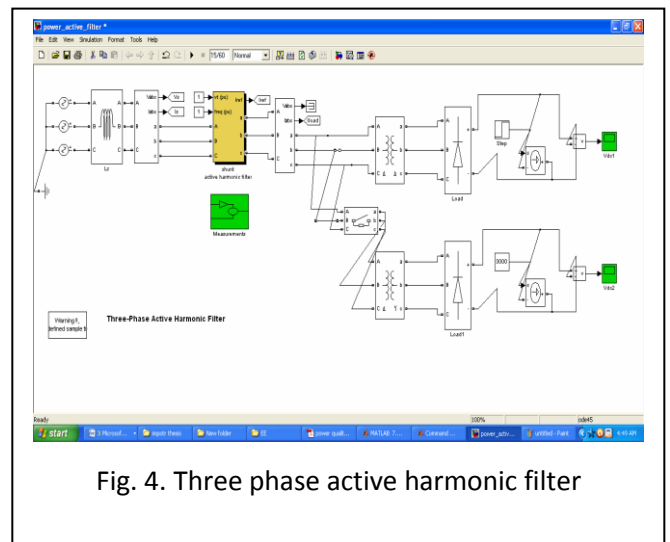

Fig. 4. Three phase active harmonic filter

6 SIMULATION REPRESENTATION OF ACTIVE POWER FILTERS

7 SIMULATION RESULTS

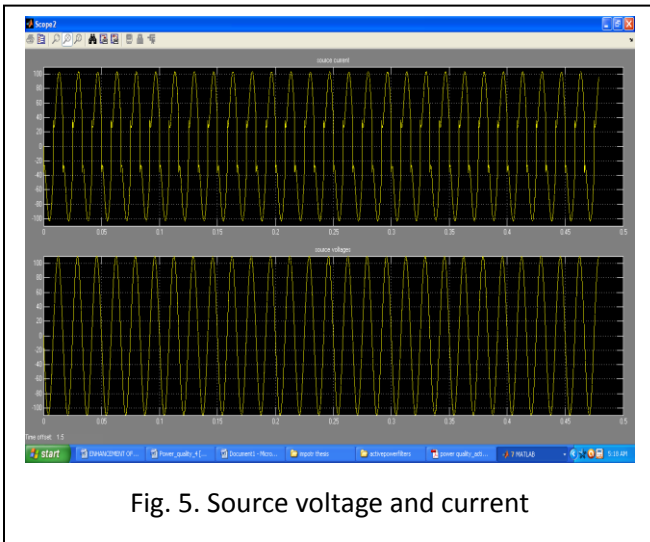

Fig. 5. Source voltage and current

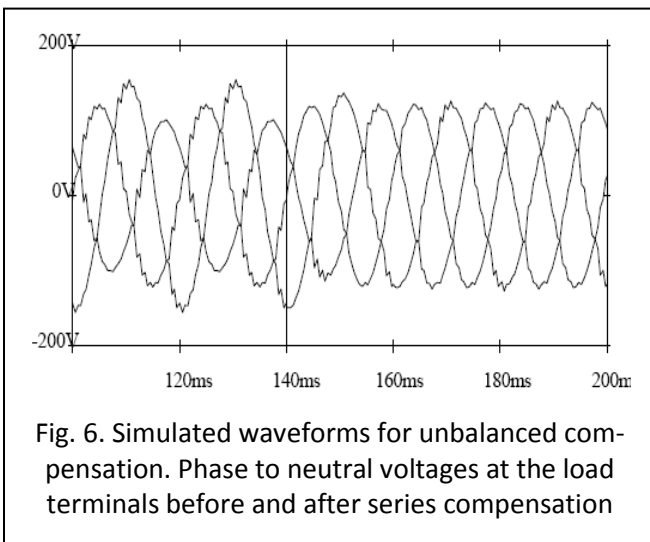

Fig. 6. Simulated waveforms for unbalanced compensation. Phase to neutral voltages at the load terminals before and after series compensation

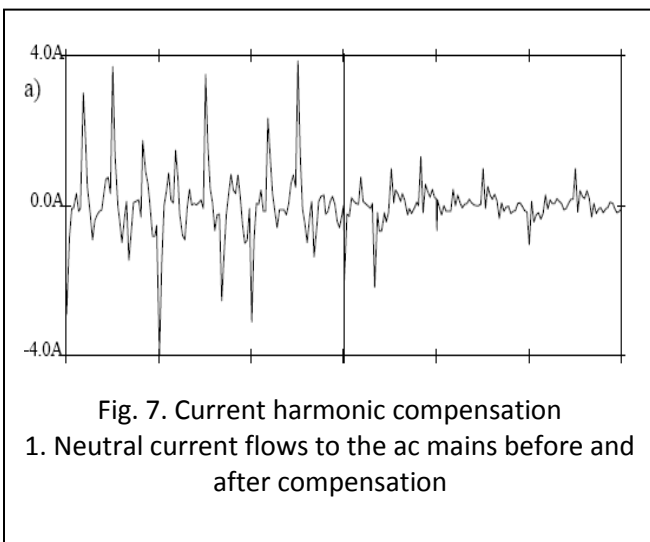

Fig. 7. Current harmonic compensation
1. Neutral current flows to the ac mains before and after compensation

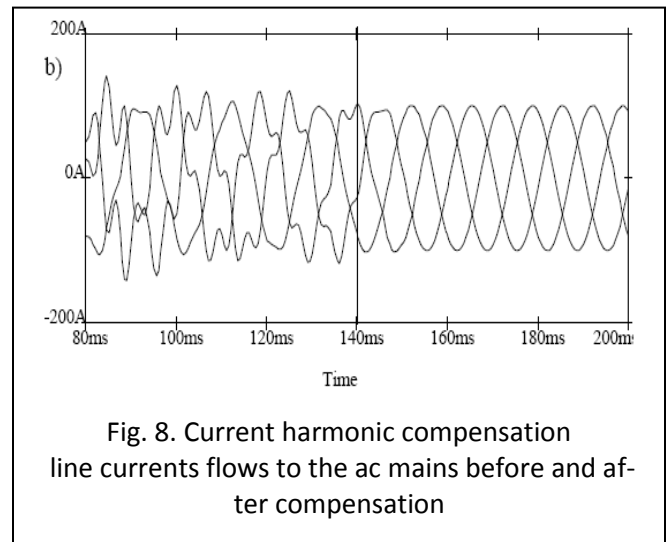

Fig. 8. Current harmonic compensation
line currents flows to the ac mains before and after compensation

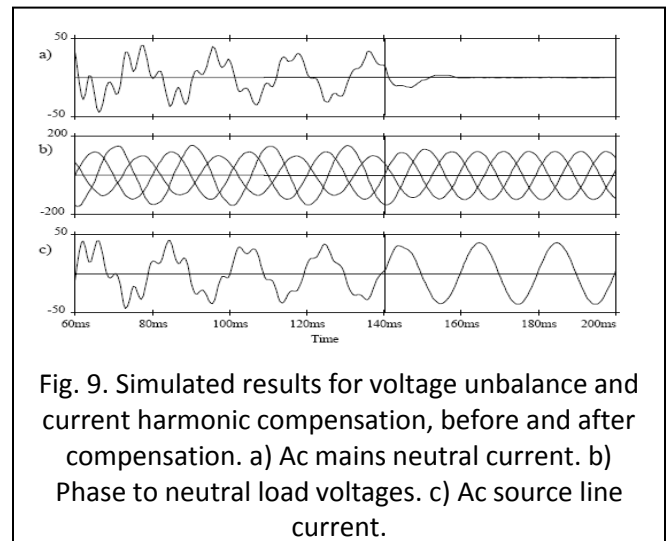

Fig. 9. Simulated results for voltage unbalance and current harmonic compensation, before and after compensation. a) Ac mains neutral current. b) Phase to neutral load voltages. c) Ac source line current.

8 CONCLUSION

In this work the advantages of applying active power filters to compensation power distribution systems has been presented. The principles of operation of shunt, series, Also, a brief description of the state of the art in the active power filter market has been described. The shunt active power filter performance under fault power distribution system was discussed. Simulation results proved the viability of using active power filters to compensate active power filters.

ACKNOWLEDGMENT

I wish to thank Dr.M.Surya Kalavathi and Dr.T.Devaraj for their sincere support and clear guidance in successful completion of this work.

REFERENCES

- [1] K. Eichert, T. Mangold, M. Weinhold, "Power Quality Issues and their Solution", in VII Seminario de Electrónica de Potencia, Valparaíso, Chile, Abril 1999.

- [2] M. Rahmani, A. Arora, R. Pfister, P. Huencho, "State of the Art Power Quality Devices and Innovative Concepts", in VII Seminario deE-lectrónica de Potencia, Valparaíso, Chile, Abril 1999.
- [3] J. K. Phipps, J.P. Nelson, P. K. Sen, "Power Quality and Harmonic Distortion on Distribution Systems", in IEEE Trans. on Ind. Appl., vol. 30, No 2, March/ April 1994, pp. 176-184.
- [4] Y.H. Yan, C.S. Chen, C.S. Moo, and C.T. Hsu, "Harmonic Analysis for Industrial Customers", in IEEE Trans. on Ind. Appl., vol. 30, No 2, March/April 1994, pp. 462-468.
- [5] G. Joos, L. Morán, "Principles of Active Power Filters", Tutorial Course Note. of IEEE Ind. Appl. Society Annual Meeting, Oct. 1998.
- [6] W. M. Grady, M.J. Samotyj, A. H. Noyola, "Survey of Active Power Line Conditioning Methodologies", in IEEE Trans. on Power Delivery, vol. 5, no 3, pp.1536-1542, July 1990.
- [7] H. Akagi, "New Trends in Active Filters for Power Conditioning," in IEEE Trans. on Industry Applications, vol. 32, no. 6, pp. 1312-1322, Nov./Dec. 1996
- [8] M. Aredes, K. Heuman and E. Watanabe, "An Universal Active Power Line Conditioner," in IEEE Trans. on Power Delivery, vol. 13, no 2, pp. 545-551, April 1998.
- [9] L. Moran, L. Fernández, J. Dixon, R. Wallace, "A Simple and Low Cost Control Strategy for Active Power Filters Connected in Cascade", in IEEE Trans. on Industrial Electronics, vol. 44, no. 5, pp.621-629, Oct. 1997.
- [10] C. Mel horn, T. Davis, G. Beam, "Voltage Sags: Their Impact on the Utility and Industrial Customers", in IEEE IAS Trans. on Ind. Appl., Vol. 34, No. 3, May/June 1998, pp. 549-558